



# RAMPBALL® MOUNTING

Rampball® – tilting and rotating balance ball

4 versions; Ø35 cm tilting

Ø50 cm tilting

Ø50R cm tilting and rotating

Ø70R cm tilting and rotating

FOR MOUNTING ON

**GRASS OR LOOSE FILL GROUND COVERS**

**rampline®**

The product is developed and assembled by Rampline AS in Norway

[rampline.com](https://www.rampline.com)

Rampball® is certified by TÜV according to EN 1176-1:2017 and EN 16630:2015

# CONTENT

About the product	3
Product parts	4
Safety zone and distances	5
Casting of foundations	6
Mounted device	7
Attaching the spring assembly	8
Mounting on <b>grass</b>	9
Mounting on <b>loose fill grund covers</b>	12

# ABOUT THE PRODUCT

## RAMPBALL®

Rampball® is a spring mounted balance ball. The product is designed for use by all age groups in public spaces meant for play and physical activity, like schoolyards, urban spaces, parks etc. The product is delivered in 4 versions; tilting versions with 35 or 50 cm diameter, and tilting and rotating versions with 50 or 70 cm diameter.

## MOUNTING

Rampball® can be mounted on different kinds of ground covers (grass, artificial grass, wet pour and loose fill covers).

This description is for mounting on **grass** and **loose fill covers**.

Mounting time approx 30-45 min, 1 person.

## SAFETY

The device requires a shock absorbing ground cover approved for a 100 cm fall height, according to EN 1176-1:2017 / 4.2.8.5.3

The product is certified by TÜV according to EN 1176-1:2017 and EN 16630:2015

## INCLUSIVE DESIGN

The product is designed to be accessible and fun for all users, including users with disabilities. Rampline recommends using a ground cover that does not obstruct anyone in accessing the device. Avoid edges or steps etc. that may pose hindrances for some users. Read more about inclusive design and our products at [rampline.com](http://rampline.com).

## OWNER'S AND INSTALLER'S RESPONSIBILITY

Only parts delivered with the product shall be used. Rampline is not responsible for errors or damages as a result of the use of components not delivered by Rampline AS.

The owner is obliged to comply with the OMA and imposed safety requirements for the device.

# PRODUCT PARTS

Parts	<b>Rampball®35</b> Ø350 mm Tilting	<b>Rampball®50</b> Ø500 mm Tilting	<b>Rampball®50R</b> Ø500 mm Tilting and rotating	<b>Rampball®70R</b> Ø700 mm Tilting and rotating
Rubber/EPDM ball	Ø350 mm	Ø500 mm	-	-
Rubber/EPDM ball with ball bearing	-	-	Ø500 mm	Ø700 mm
Spring assembly	length 200 mm	length 280 mm	length 140 mm	length 210 mm
Expansion bolt	4 pcs 115 x 10 mm	4 pcs 115 x 10 mm	4 pcs 115 x 10 mm	4 pcs 140 x 12 mm
Washer	4 pcs 14 mm	4 pcs 14 mm	4 pcs 14 mm	4 pcs 14 mm
Spacer tubes	4 pcs 20 mm	4 pcs 20 mm	4 pcs 20 mm	4 pcs 20 mm
Locking washer	4 pcs Ø10 mm	4 pcs Ø10 mm	4 pcs Ø10 mm	4 pcs Ø12 mm
Anchoring bolt	2 pcs 12 x 60 mm	2 pcs 12 x 100 mm	2 pcs 12 x 40 mm	3 pcs 14 x 50 mm
Washer	2 pcs 12 mm	2 pcs 12 mm	2 pcs 12 mm	3 pcs 14 mm
Locking washer	2 pcs 12 mm	2 pcs 12 mm	2 pcs 12 mm	3 pcs 14 mm

Parts for assembly adapted for mounting to **grass**

Mounting bracket with PE-ring and fasteners	Ø215 mm h 21,5 cm	Ø215 mm h 21,5 cm	Ø215 mm h 21,5 cm	Ø275 mm h 21,5 cm
---	----------------------	----------------------	----------------------	----------------------

Parts for assembly adapted for mounting to **loose fill ground covers**

Mounting bracket with PE-ring and fasteners	Ø215 mm h 30 cm	Ø215 mm h 30 cm	Ø215 mm h 30 cm	Ø275 mm h 30 cm
---	--------------------	--------------------	--------------------	--------------------

# SAFETY ZONE AND DISTANCES

## SAFETY ZONE

Rampball® requires a safety zone within 150 cm distance from the device. It can share safety zone with other equipment.

## REQUIRED DISTANCES BETWEEN RAMPBALLS

Multiple Rampballs can be placed in groups and courses according to EN 1176-1:2017 / 3.20 .

Required distances between Rampballs, see the drawing below wich states minimum distances (center to center) between balls of different sizes.

Measurements in cm.

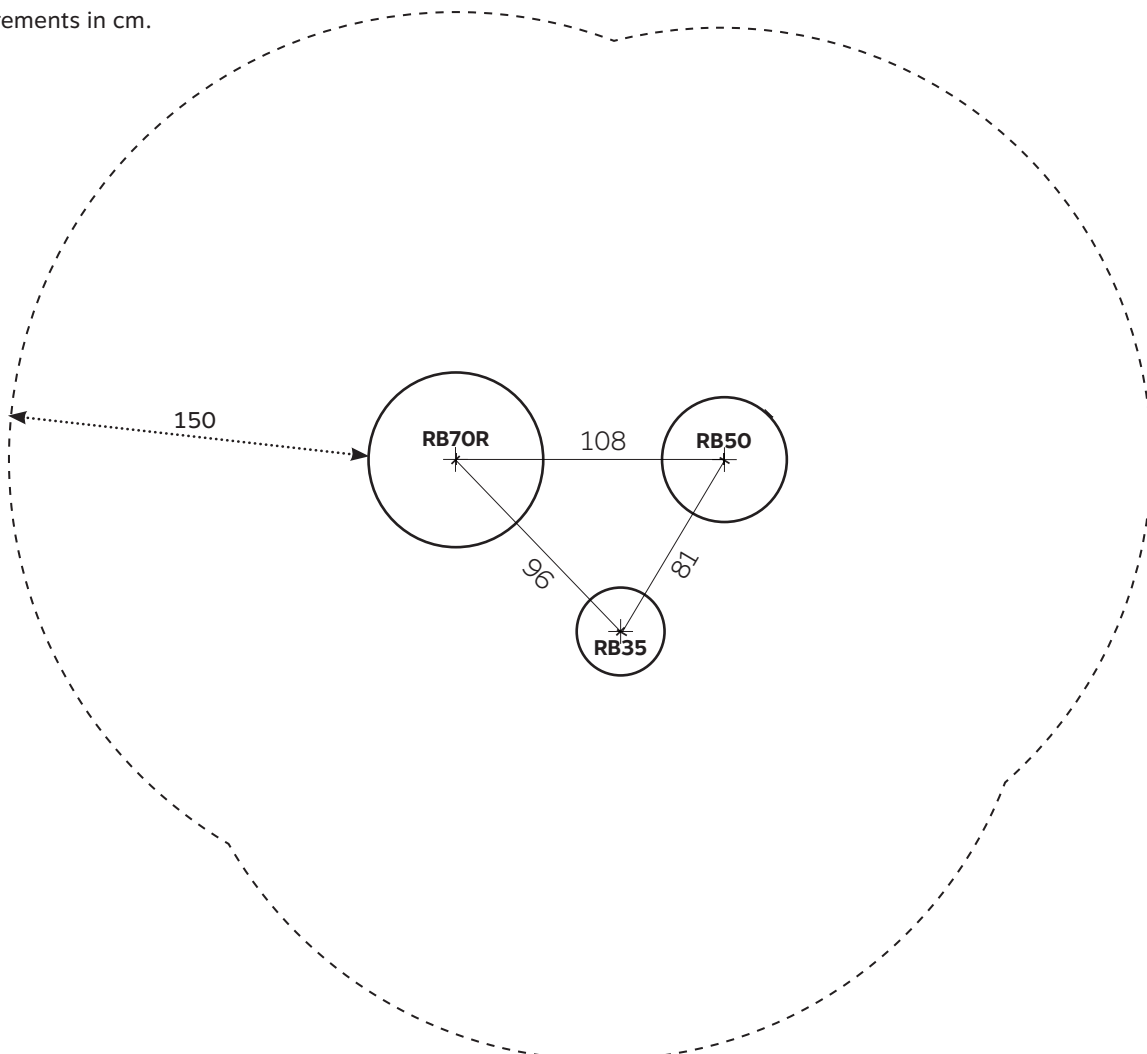

# CASTING THE CONCRETE FOUNDATION

## IMPORTANT:

- Use concrete grade minimum B30
- Never make the foundation smaller than the minimum required size.
- Even the concrete with a trowel to get a smooth surface at the attachment point.
- Let the concrete harden for at least 7 days before attaching the device to the foundation.

# MOUNTED RAMPBALL®

The mounted Rampball® should look like this:

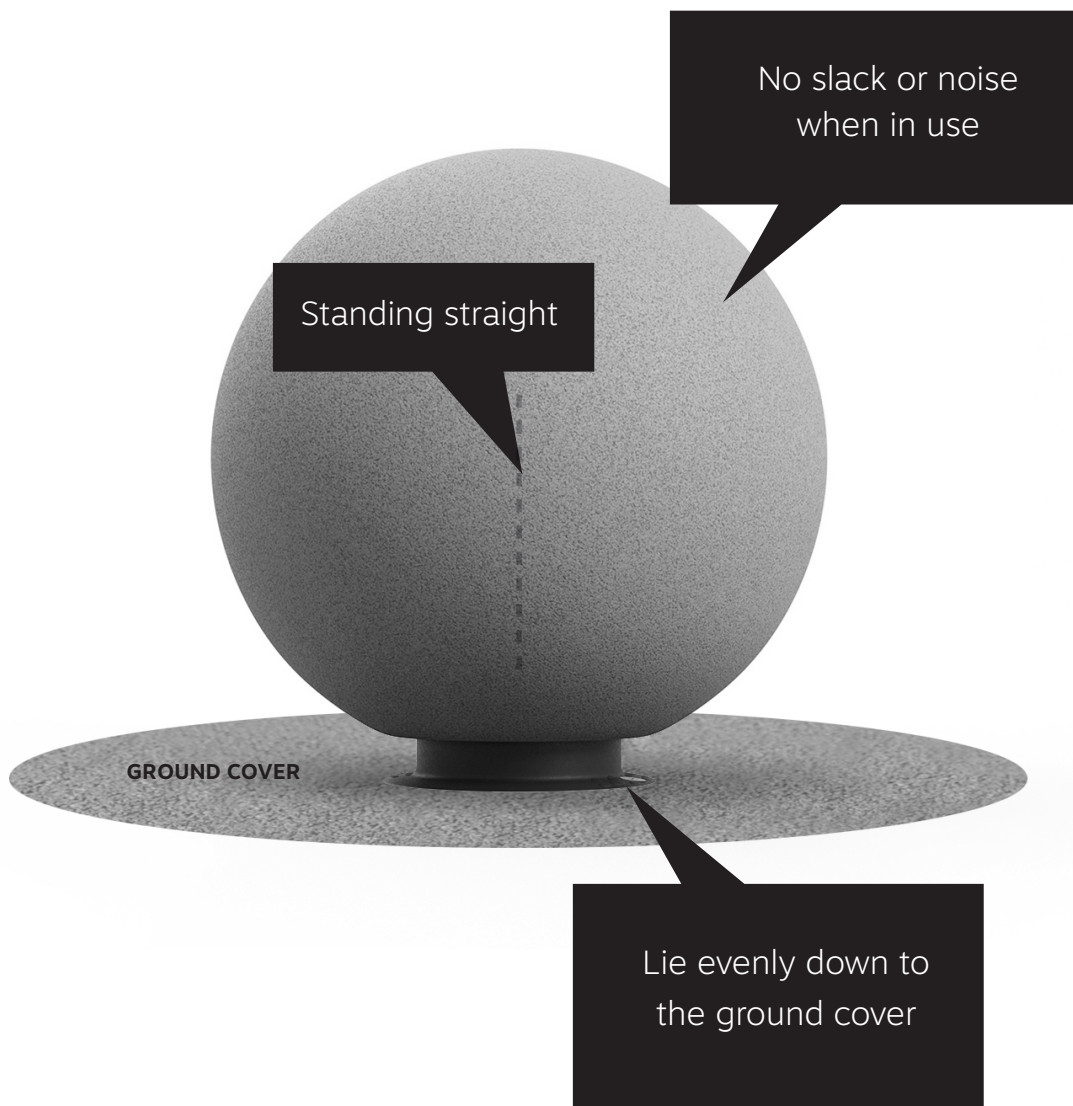

## ATTACHING THE SPRING ASSEMBLY

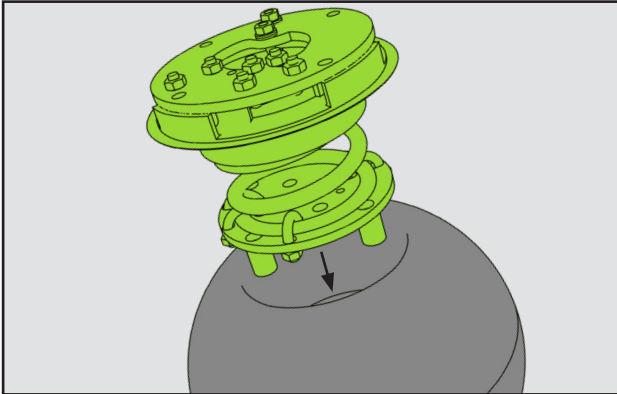

Insert the spring assembly into the ball.

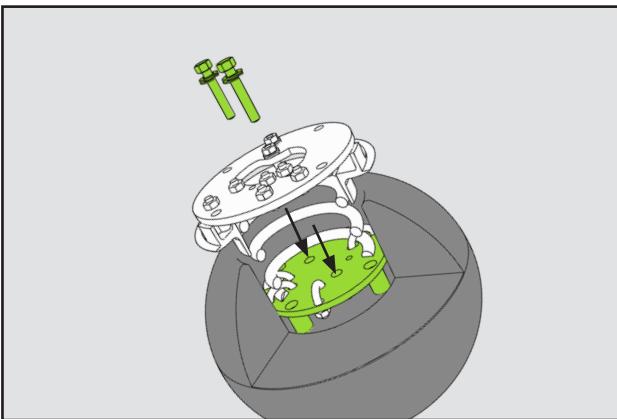

Find the right position in order for the bolts to match the holes in the ball.

2 bolts with washers and locking washers  
(3 bolts for version Rampball® 70R).

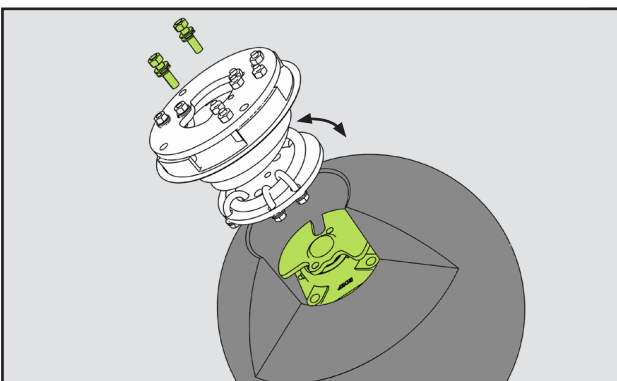

### For versions with rotation:

(Rampball® 50R and Rampball® 70R):

It is important that the spring assembly's mounting plate and the mounting plate at the bottom of the ball are placed in the correct position relative to each other. The plates should fit tight together.

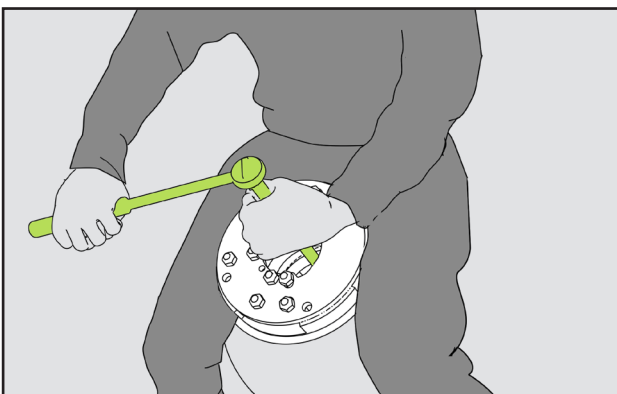

Insert the bolts and tighten them properly.

Use a 19 mm socket wrench (22 mm for Rampball 70R) with an extender.

To obtain enough force, sit on the ball and pinch the spring assembly between the legs.



# MOUNTING ON GRASS

## The mounting is performed in 3 steps

- 1) Cast the foundation
- 2) Attach the mounting bracket to the foundation
- 3) Attach the device on the mounting bracket

## Equipment needed:

• Small sledgehammer • Hammer drill with 10 mm bit (12 mm for Rampball 70R) • Measuring tape

Included: • Socket wrench 17 mm • Steel pipe

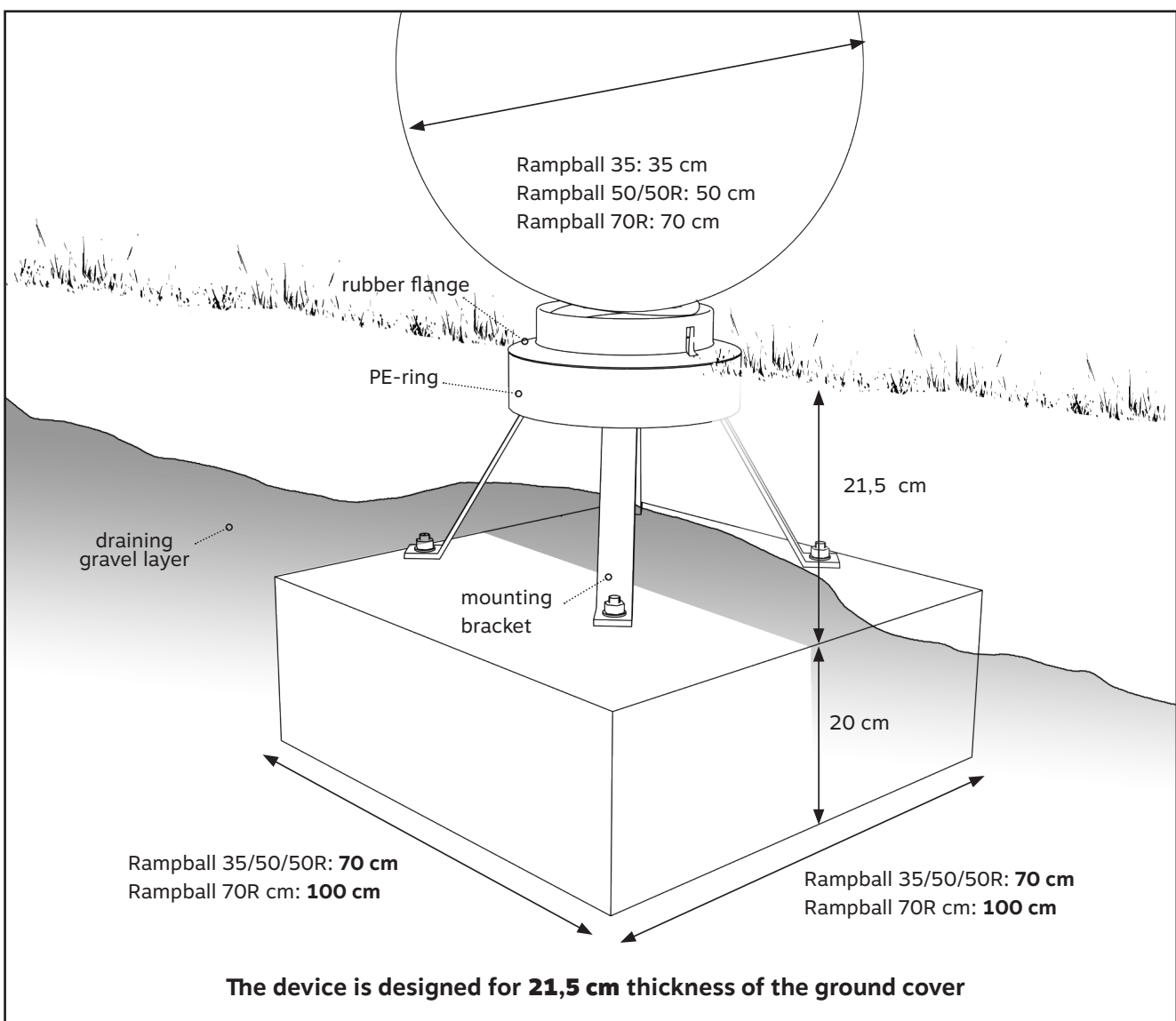

## MOUNTING

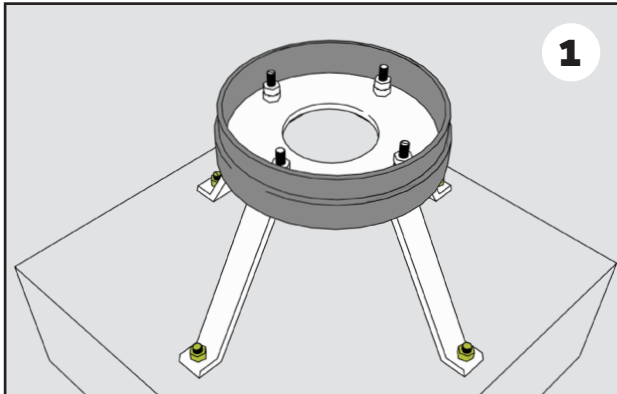

**Place the mounting bracket with the PE-ring on foundation's center.**

Drill holes and fasten the 4 legs of the mounting bracket to the concrete foundation using the supplied expansion bolts.

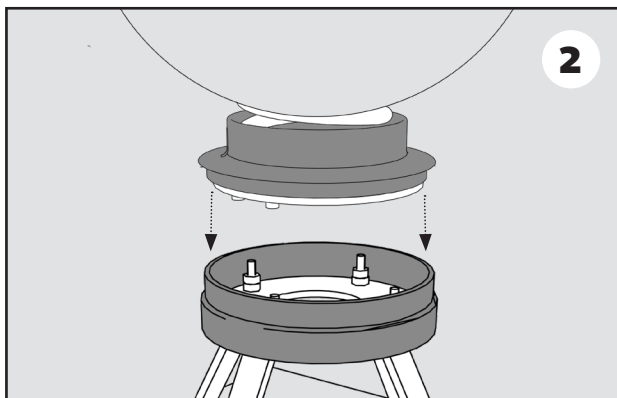

**Place the Rampball carefully into the PE ring with the bolts in position to match the bolt holes.**

(With the largest version Rampball 70R, 2 persons are required. Use a pallet jack trolley or other lifting aid.)

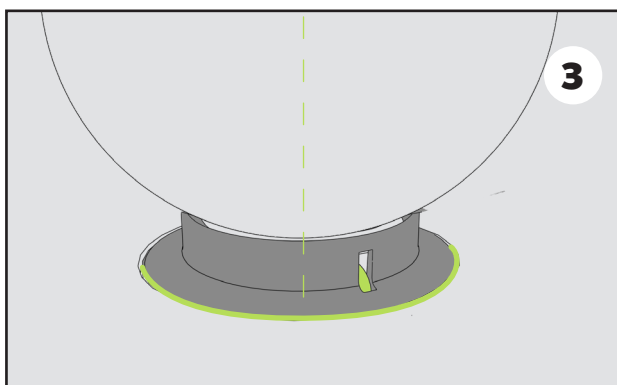

**Check before fastening.**

Check that the Rampball is standing straight in 90 degrees. The flange should fit inside the PE ring. If the U-bolt is visible through the hole on the side of the rubber flange the device is correctly positioned.

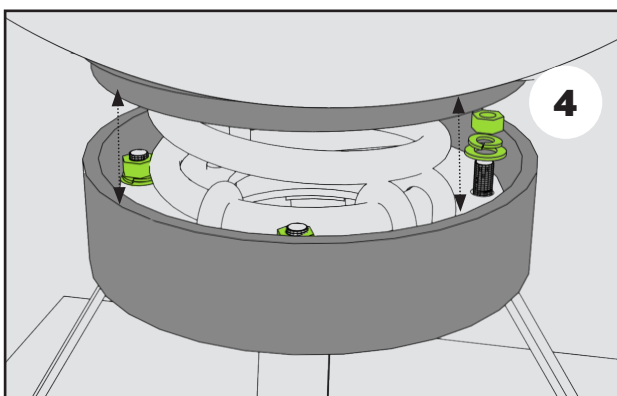

**Install the washers, lock washers and the nuts on the 4 bolts and tighten.**

Lift the rubber flange for access. When washers and nuts are attached, lower the flange back into position.

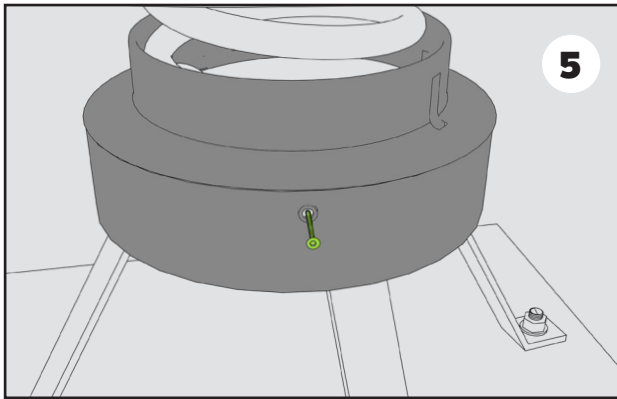

**Attach the rubber flange to the PE ring.**

Screw the 2 supplied screws into the pre-drilled holes of the ring. The screws should go through the PE ring as well as through the wall of the rubber flange.

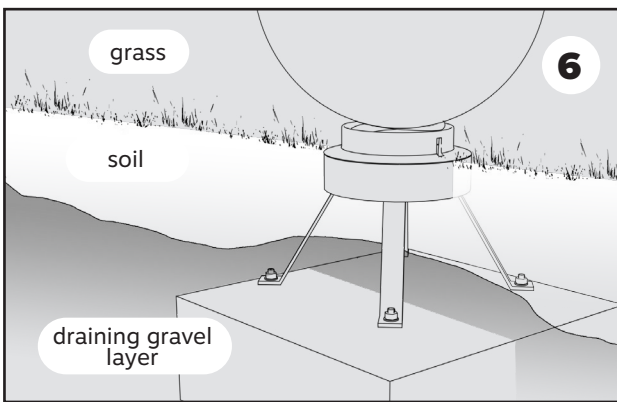

**Fill with draining gravel, soil and apply grass on top.**

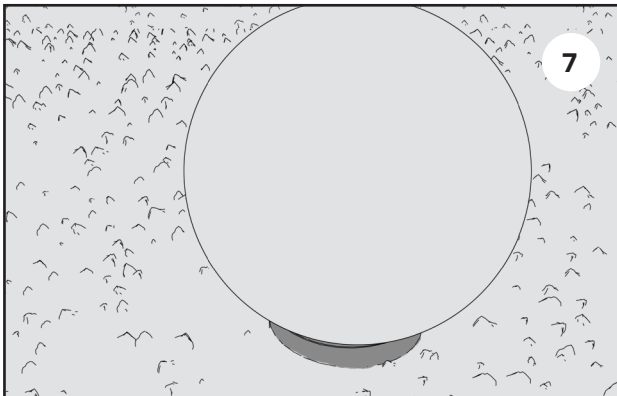

**Rampball is now fully mounted.**

Top up soil layer to the edge of the PE ring after some time if it has sunk.

# MOUNTING ON LOOSE FILL COVERS

## The mounting is performed in 4 steps

- 1) Cast the foundation
- 2) Attach the mounting bracket
- 3) Mount the device to the mounting bracket
- 4) Fill with shock absorbing aggregates

## Equipment needed:

• Small sledgehammer • Hammer drill with 10 mm bit • Measuring tape

Included: • Socket wrench 17 mm • Steel pipe

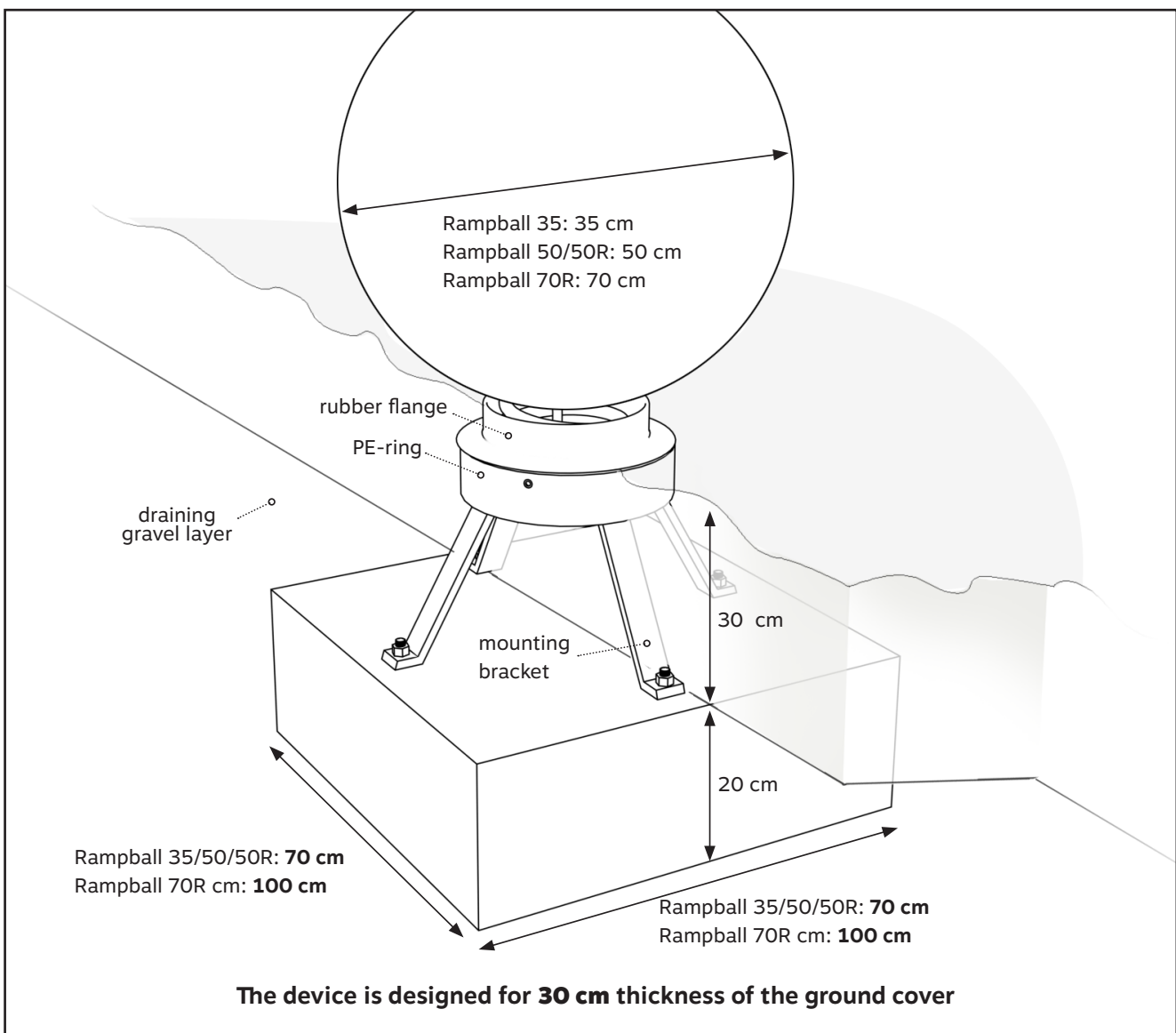

## MOUNTING

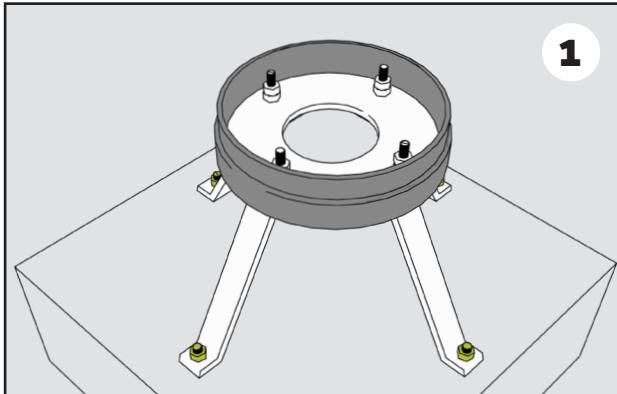

**Place the mounting bracket with the PE-ring on foundation's center.**

Drill holes and fasten the 4 legs of the mounting bracket to the concrete foundation using the supplied expansion bolts.

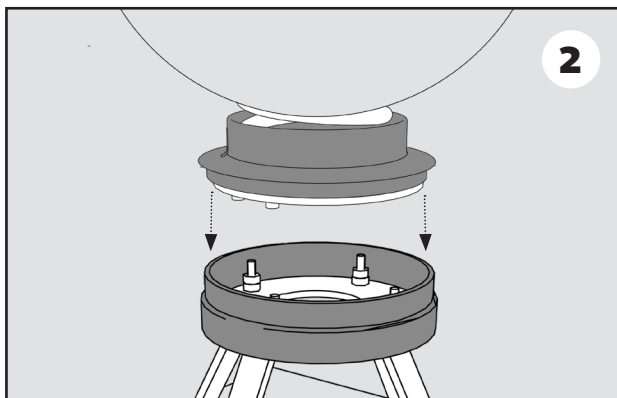

**Place the Rampball carefully into the PE ring with the bolts in position to match the bolt holes.**

(With the largest version Rampball 70R, 2 persons are required. Use a pallet jack trolley or other lifting aid.)

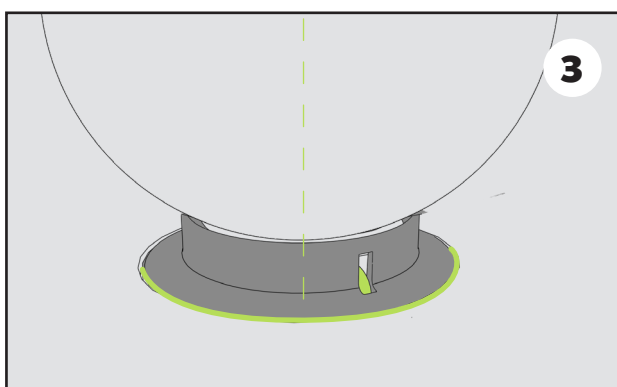

**Check before fastening.**

Check that the Rampball is standing straight in 90 degrees. The flange should fit inside the PE ring. If the U-bolt is visible through the hole on the side of the rubber flange the device is correctly positioned.

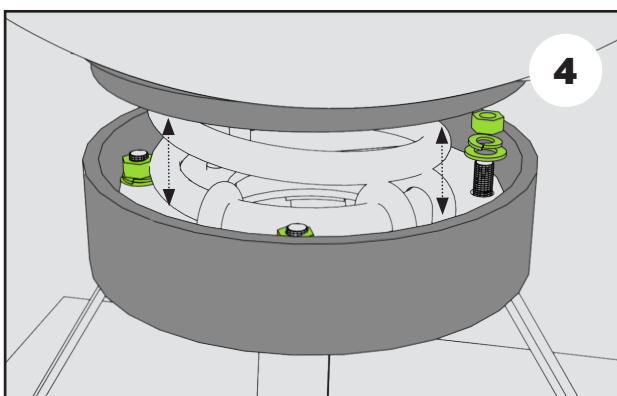

**Install the washer, lock washer and the nut on the 4 bolts and tighten.**

Lift the rubber flange for access. When washers and nuts are attached, lower the flange back into position.

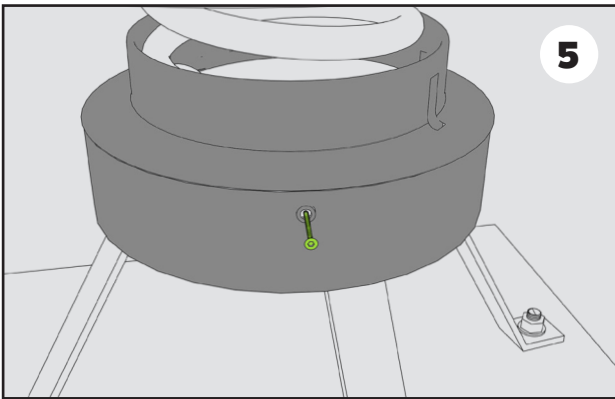

**Attach the rubber flange to the PE ring.**

Screw the 2 supplied screws into the pre-drilled holes of the ring. The screws should go through the PE ring as well as through the wall of the rubber flange.

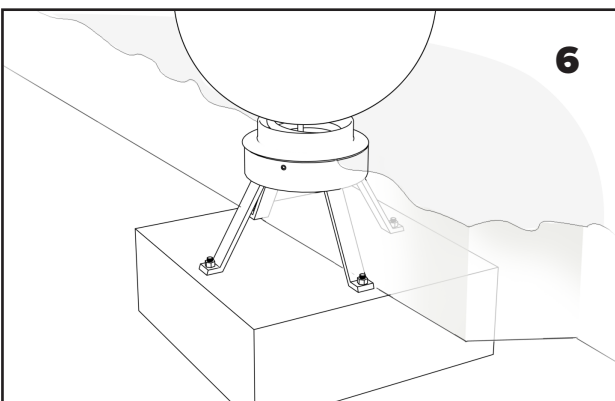

**Fill up with aggregates to the edge of the rubber flange.**

**Rampball is now fully mounted.**

# MOUNTING ON WET POUR COVERS

## The mounting is performed in 4 steps

- 1) Cast the foundation
- 2) Put the styrofoam placeholder in place
- 3) Pour the ground cover
- 4) Remove the placeholder and mount the device

## Equipment needed

- Small sledgehammer · Knife · Hammer drill with 10 mm bit (12 mm for Rampball 70R)
  - Measuring tape
- Included: · Socket wrench 17 mm · Steel pipe

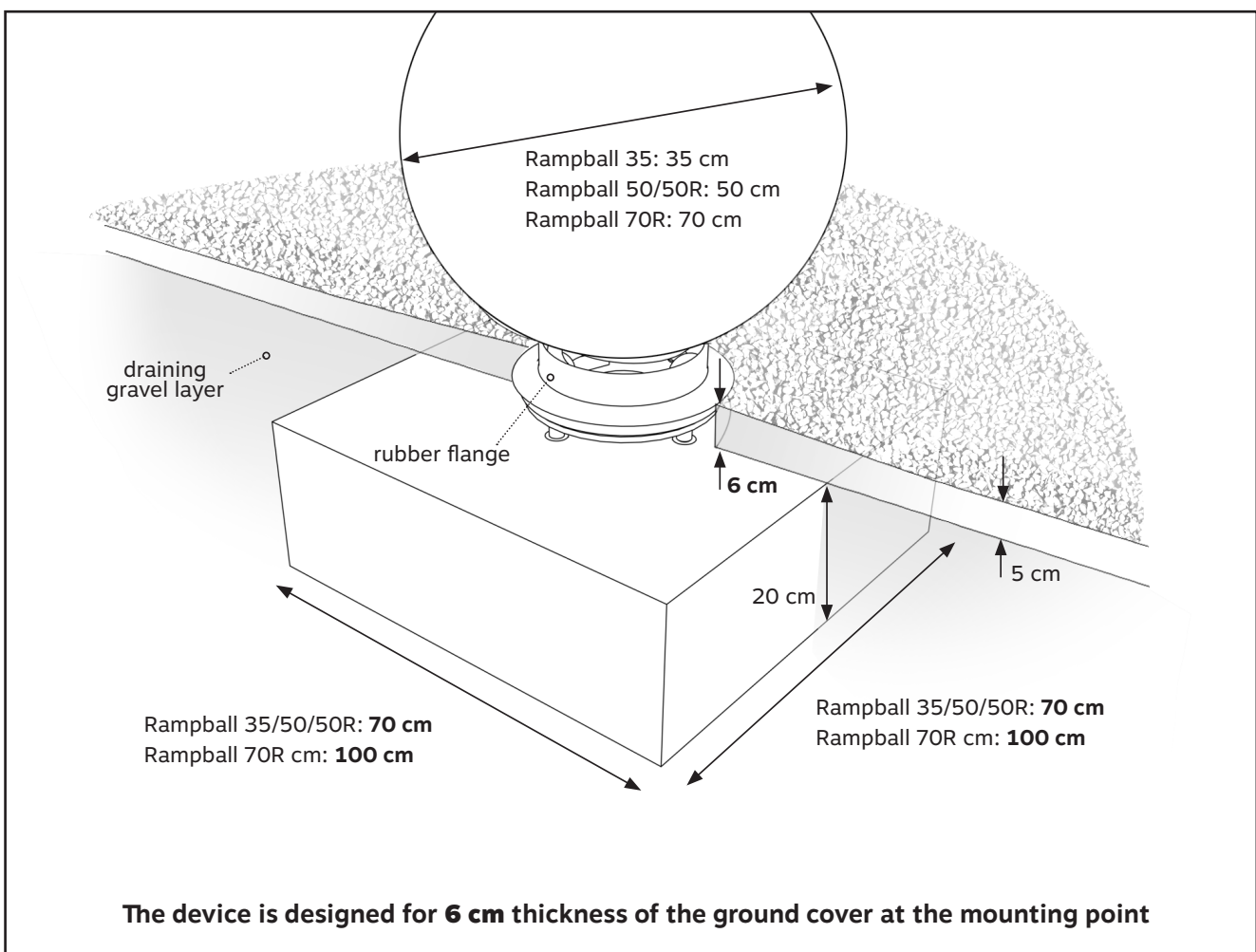

## WHEN POURING THE GROUND COVER

A mounting hole for the device must be prepared using the included styrofoam placeholder.

**Important!** The design of the device requires the thickness of the ground cover to be **6 cm**.

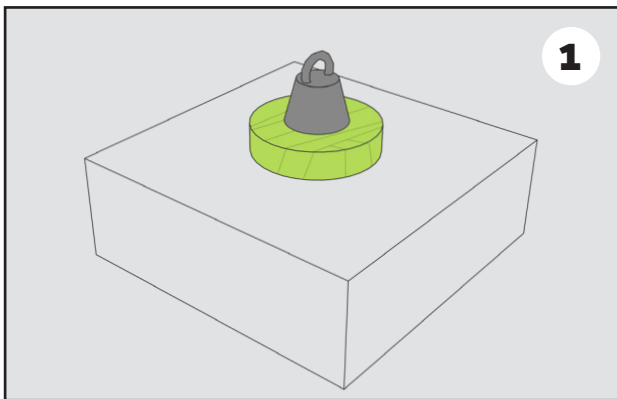

### Before pouring the ground cover:

Place the styrofoam placeholder on the concrete foundation.

Put a stone or heavy weight on the placeholder to hold it in place.

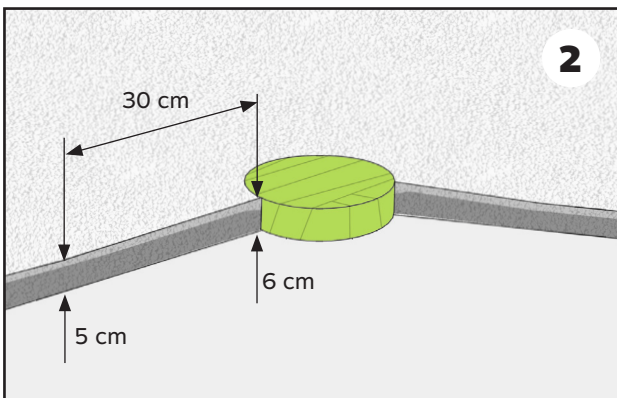

### Pour the ground cover to level with the top of the placeholder.

The ground cover should have the same thickness as the placeholder (6 cm) at the mounting hole.

If desired the thickness can be tapered down to 5 cm at about 30 cm from the mounting hole.



## MOUNTING

After the ground cover is poured and cured.

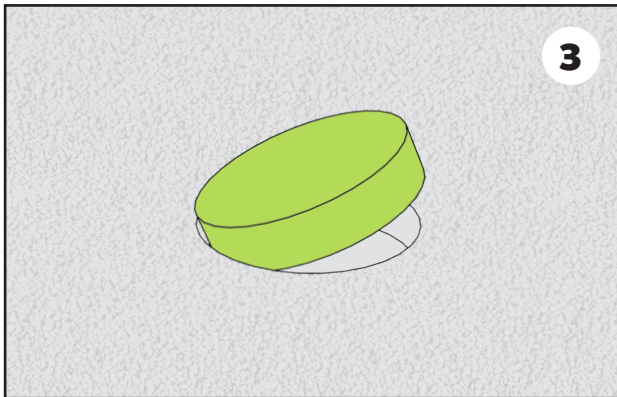

### Remove the placeholder.

Use a knife to pull it out of the mounting hole.

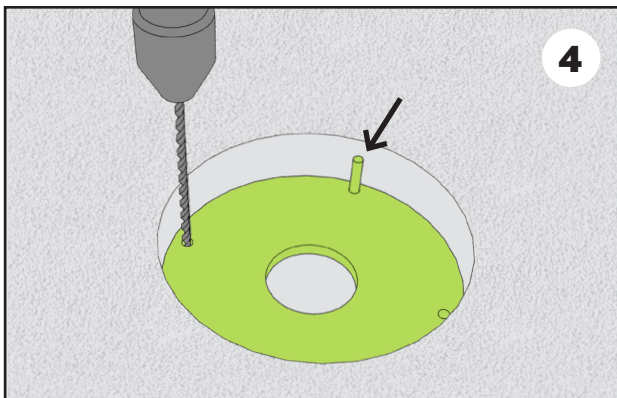

### Drill 4 holes using the drill template.

Drill in a perpendicular angle into the concrete.

When the first hole is done, fix the drill template in position with the supplied steel pin (arrow).

Drill the 3 remaining holes.

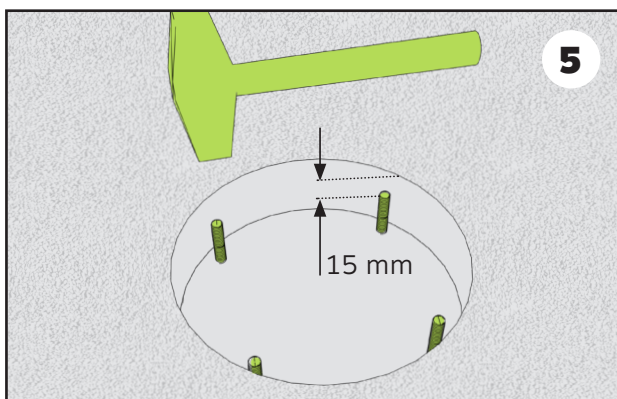

### Hammer down the expansion bolts.

The level of the top of the bolts should be 15 mm below the surface of the poured ground cover.

Use a small sledgehammer and be careful not to damage the bolts.

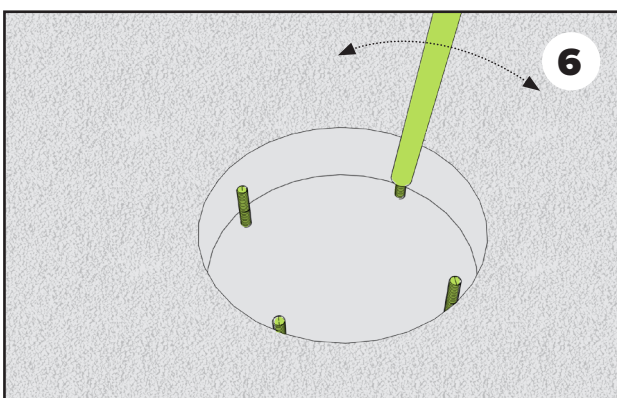

### Adjust bolts if necessary.

Place the drill template on the bolts and check that they match the holes.

Correct the bolts if needed using the supplied steel pipe.

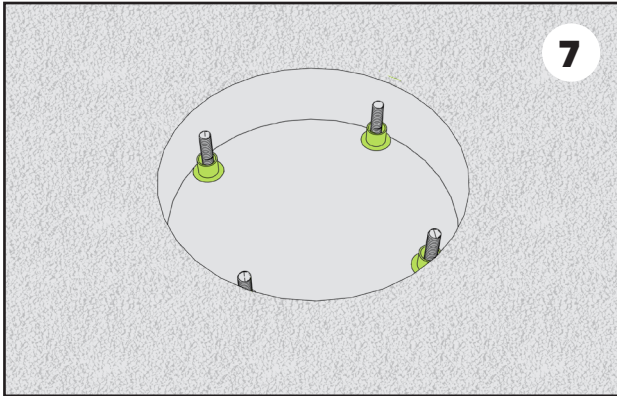

### Attach large washers and spacers.

First clean away loose particles on the concrete surface around the bolts.

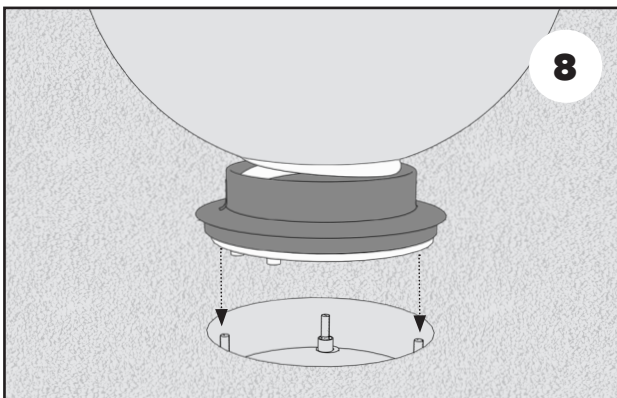

### Place the Rampball carefully into the mounting hole with the bolt holes in position to match the bolts.

(With the largest version Rampball 70R, 2 persons are required. Use a pallet jack trolley or other lifting aid.)

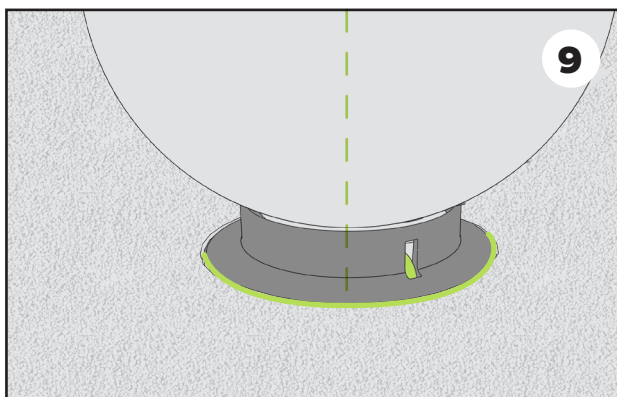

### Check before fastening.

Check that the Rampball is standing straight in 90 degrees. The flange should fit easily inside the mounting hole and rest on the ground. If the U-bolt is visible through the hole on the side of the rubber flange the device is correctly positioned.

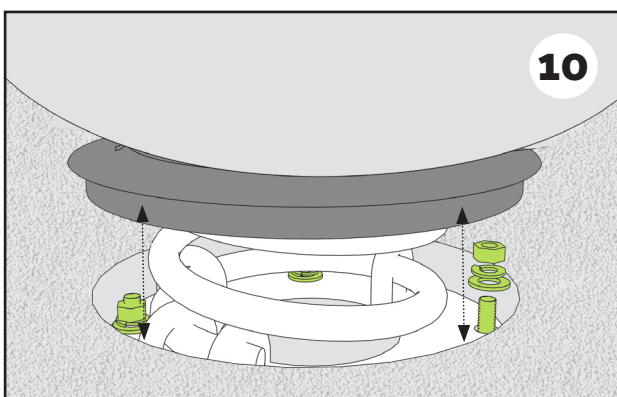

### Install the washer, lock washer and the nut on the 4 bolts and tighten.

Lift up the rubber flange for access. When washers and nuts are attached, lower the flange back into position.

**Jumpstone is now fully mounted.**

# MOUNTING ON ARTIFICIAL GRASS

## The mounting is performed in 4 steps

- 1) Cast the foundation
- 2) Mount the PETG-ring on the foundation
- 3) Lay the artificial grass
- 4) Mount the device

## Equipment needed:

- Small sledgehammer • Hammer drill with 10 mm bit (12 mm for Rampball 70R)
- Measuring tape • Wallpaper knife

Included: • Socket wrench 17 mm • Steel pipe

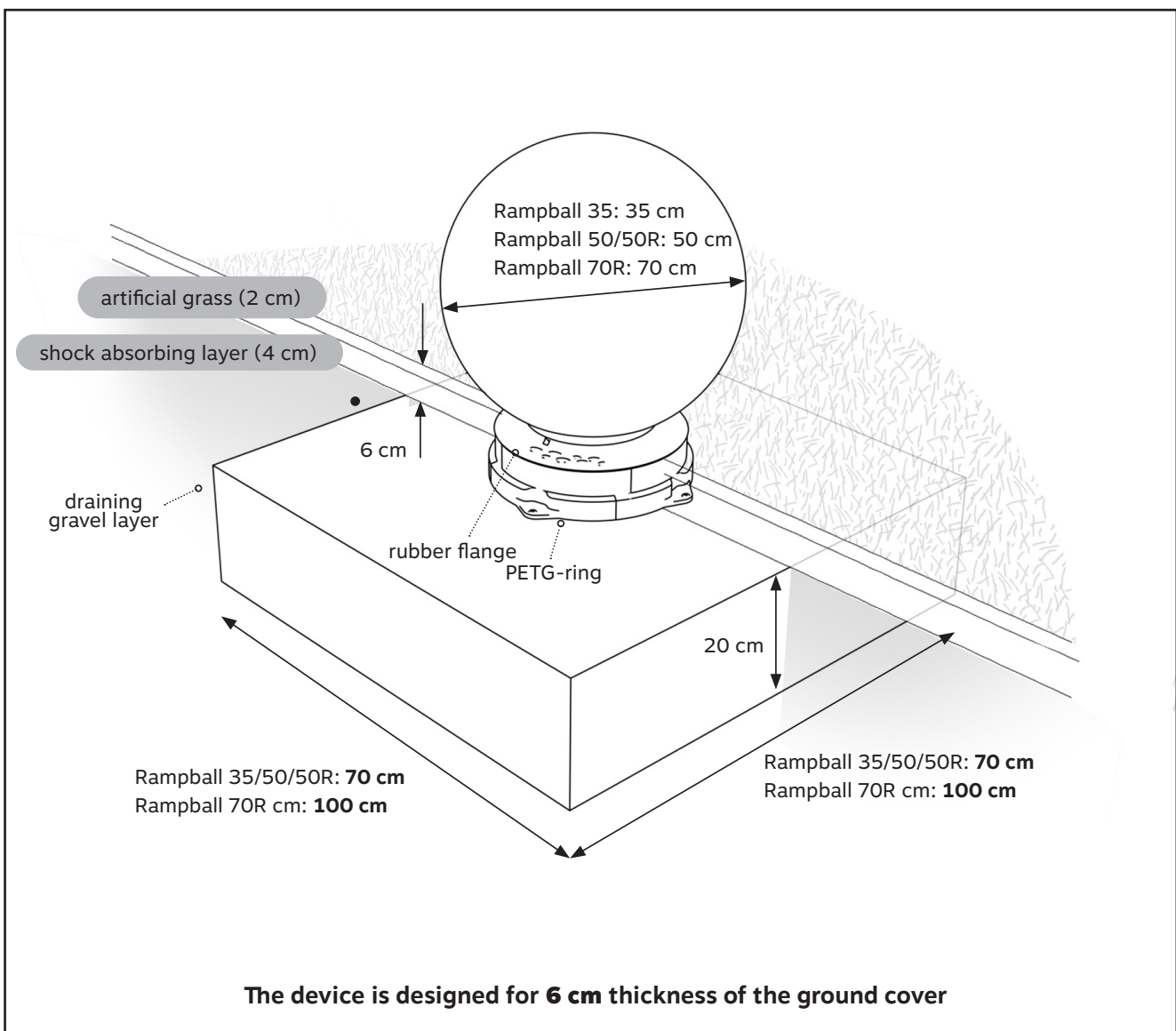

## MOUNTING

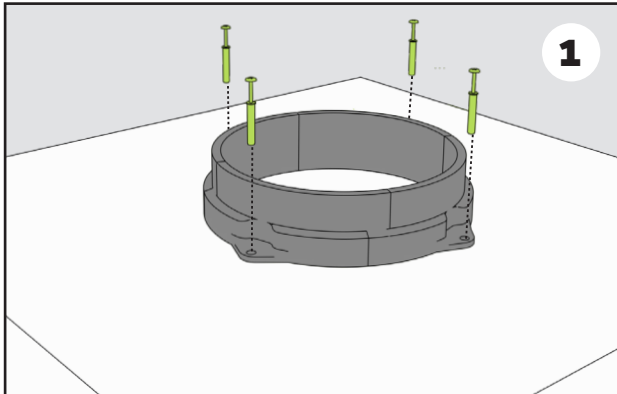

**Attach the PETG-ring to the concrete foundation.**

Drill 3 holes and use the included screws and plugs.

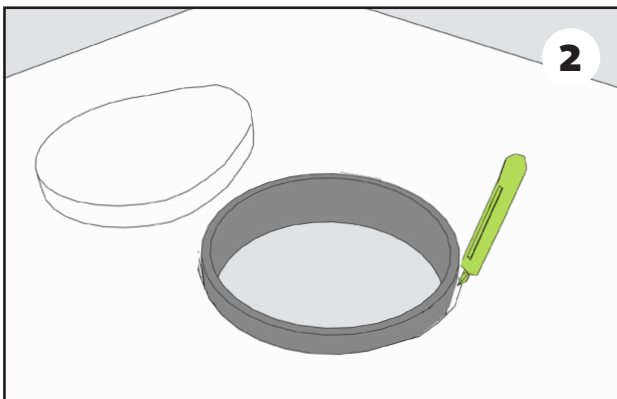

**Cut the shock absorbing layer along the outside edge of the PETG-ring.**

Lay the mat tight to the PETG-ring.

Use a sharp wallpaper knife.

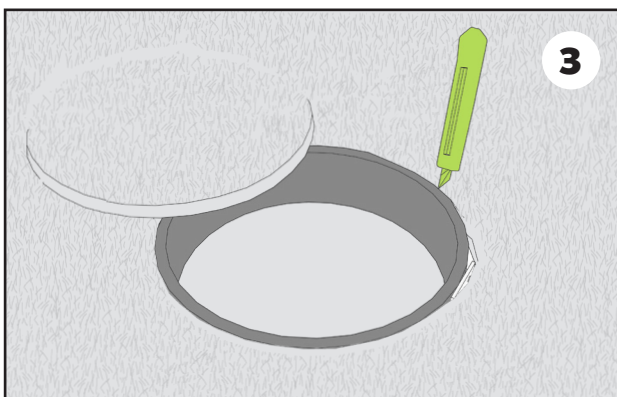

**Cut the artificial grass layer along the outside edge of the PETG-ring.**

Lay the artificial grass tight to the plastic shield.

Use a sharp wallpaper knife .

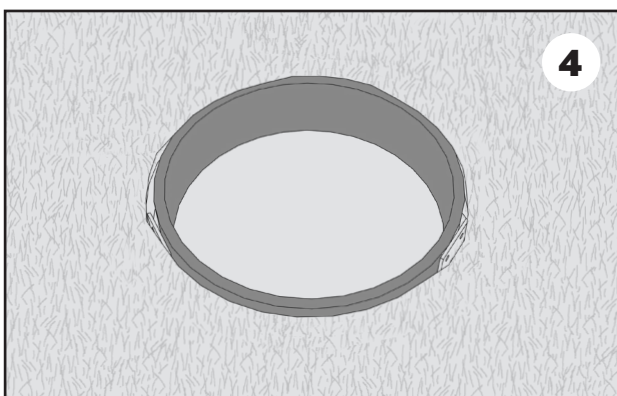

**The mounting hole is now ready for mounting the Rampball.**



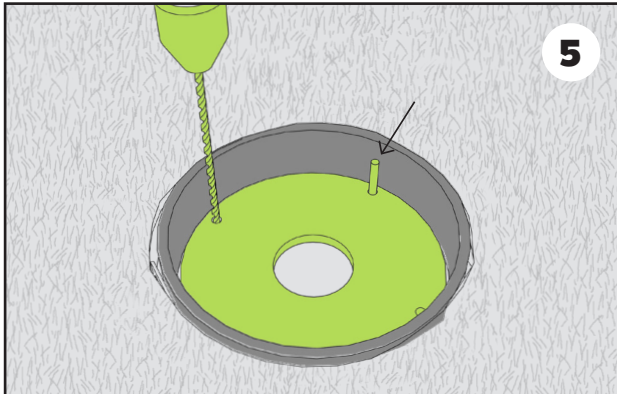

#### Drill 4 holes using the drill template.

Drill in a perpendicular angle into the concrete.

When the first hole is done, fix the drill template in position with the supplied steel pin (arrow).

Drill the 3 remaining holes.

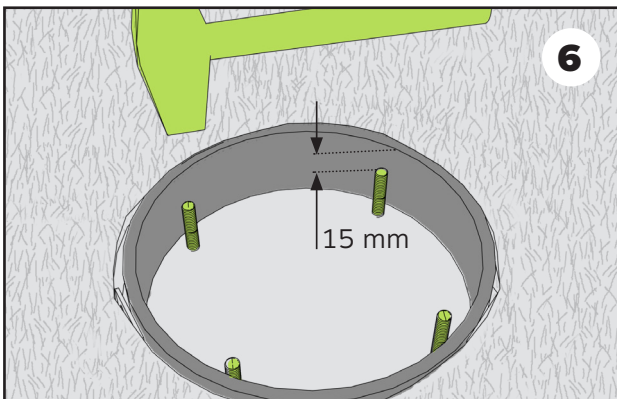

#### Hammer down the expansion bolts.

The level of the top of the bolts should be **15 mm below** the surface of the poured ground cover.

Use a small sledgehammer and be careful not to damage the bolts.

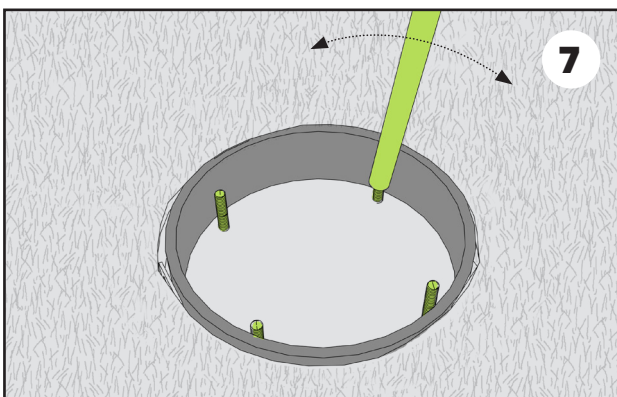

#### Adjust bolts if necessary.

Place the drill template on the bolts and check that they match the holes.

Correct the bolts if needed using the supplied steel pipe.

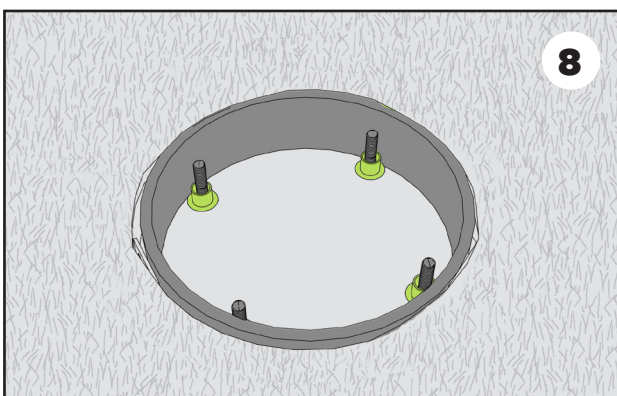

#### Attach large washers and spacers.

First clean away loose particles on the concrete surface around the bolts.

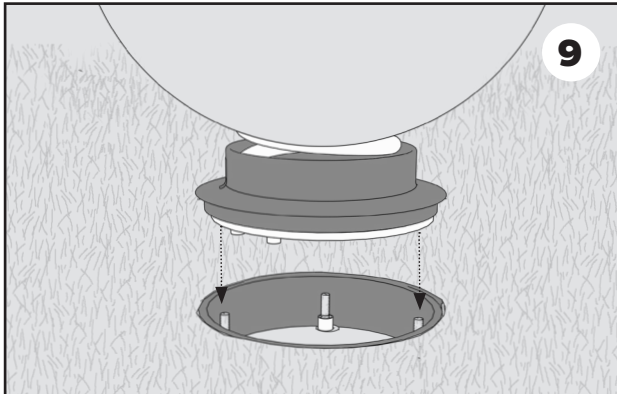

Place the Rampball carefully into the mounting hole with the bolt holes in position to match the bolts.

(With the Rampball 70R, 2 persons are required. Use a pallet jack trolley or other lifting aid.)

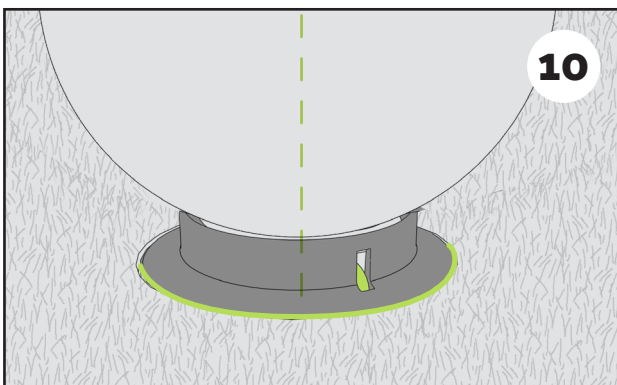

**Check before fastening.**

Check that the Rampball is standing straight in 90 degrees. The rubber flange should fit easily inside the PETG-ring. If the U-bolt is visible through the hole on the side of the rubber flange the device is correctly positioned.

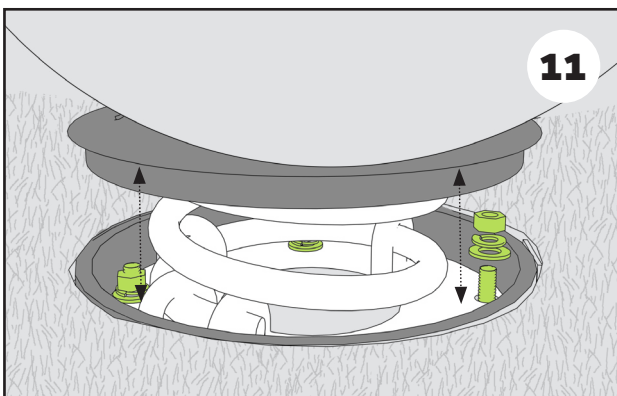

Install the **washer, lock washer and the nut on the 4 bolts and tighten.**

Lift up the rubber flange for access. When washers and nuts are attached, lower the rubber flange back into position.

**Rampball is now fully mounted.**